

**STURMEY**  
**ARCHER**  
EST. 1902



*2017 ~ 2018 / Product Catalogue*

The Original And Best Since 1902

*For 115 years, Sturmey-Archer have been pioneers in the design and manufacture of internal gear hubs, hub brakes and dynohub lighting.*



Henry Sturmey



James Archer



*This is a history of progressive research and development which has made cycling easier and safer.*

*This catalogue illustrates the complete range of Sturmey-Archer cycle components, including the latest innovations.*

[www.sturmey-archer.com](http://www.sturmey-archer.com)    [www.sturmey-archerheritage.com](http://www.sturmey-archerheritage.com)

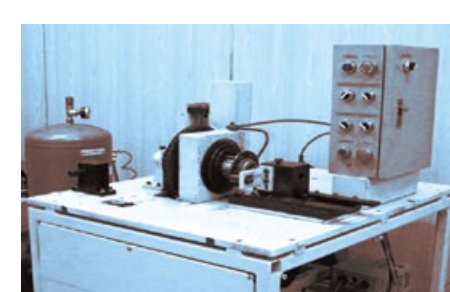
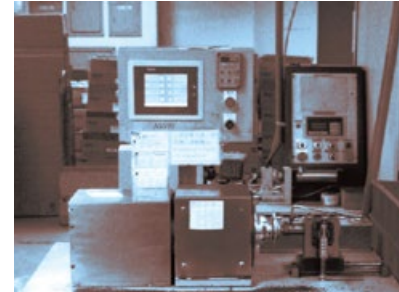
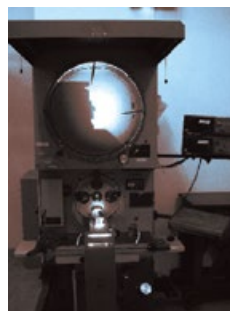



1902  
3-Speed Hub



1907  
3-Speed Coaster



1910  
X Gear Control



1910  
Catalogue



1913  
Tour de France



1918  
KB 3-Speed  
Drum Brake



1922  
CC Single  
Speed Coaster



1922  
K Gear Control



1929  
Nürnberg, Germany



1931  
Motorcycle  
Gearbox Ad



1933  
TF 2-Speed Fixed



1938  
Dynohub & TF 4-Speed



1939  
Trigger Control



1946  
ASC 3-Speed  
Fixed



1951  
Dry Battery Unit  
Fixed

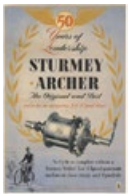

1952  
50 Years Poster



1953  
The Original And Best  
Poster



1955  
Amsterdam, NL



1962  
London-Cardiff  
Record



1966  
S5 5-Speed



1966  
S2 Kick-Shift



1968  
Chopper Shifters



1970  
Lights



1972  
Girl Poster



1977  
SBF Front Drum Brake



1978  
SAB 3-Speed  
Drum Brake



1983  
Dutch Ad



1983  
S5/2 Alloy  
5-Speed



1984  
VT 70mm Front & AT3 3-Speed  
70mm Rear



1985  
Shifters



1988  
AWC with Brass Brake



1992  
Joint Trade Ad



1995  
AT5 5-Speed  
Drum Brake



1997  
AT77 3-Speed  
Drum Brake



1997  
Orion Shifter



1999  
Summit Series



2000  
New Home Advert



**Dynohubs**

*Dynamo Hubs*

P.6



**580 (W)**

*8-Speed Hubs*

P.8

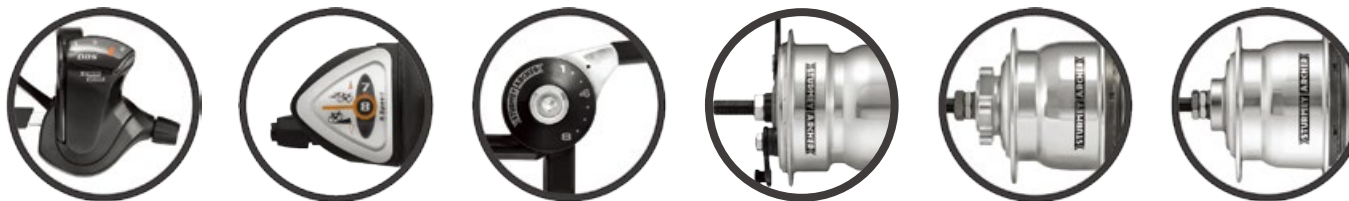

**C50**

*5-Speed Hubs*

P.11



**540**

*4-Speed Hubs*

P.14





**C30**

*Rotary 3-Speed Hubs*

*P.17*



**S30, S35**

*Classic 3-Speed Hubs*

*P.20*



**SX, QS, TS**

*Cruiser, Tricycle, Quadricycle Hubs*

*P.23*



**S3X**

*Fixed 3-Speed*

*P.26*



**F30**

*Cassette Freehub 3-Speed*

*P.30*



**S20**

*2-Speed Kick Shift*

*P.32*



**S1C, HBT, SF**

*Single Speed Coaster Brake, Hubs, Freewheels* *P.34*

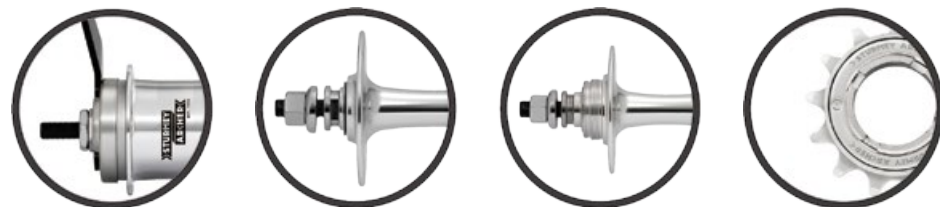

**Drum Brake Hubs**

*Front, Rear, Side Hubs*

*P.36*



**Front Cranksets**

**FCS, FCT**

**P.38**



**BL / CTS**

**Brake Levers, Chain Tensioners**

**P.42**



**Parts**

**P.43**





# Dynohubs

## Features of Dynohubs

- Dynohub in 3.0W and 6.0W.
- Integrated 90mm and 70mm drum brakes available.
- CE & EN compliance.
- Aluminum hub shells.
- Sealed cartridge bearings.
- Low rolling resistance.
- Sealed against weather conditions.

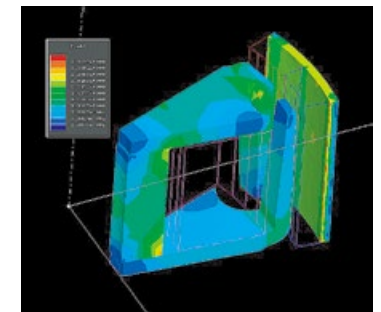
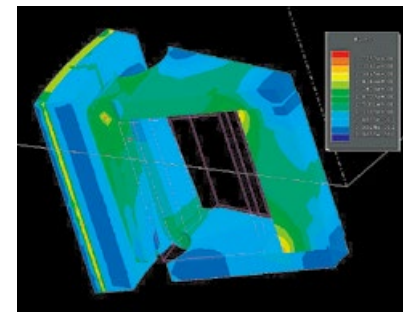
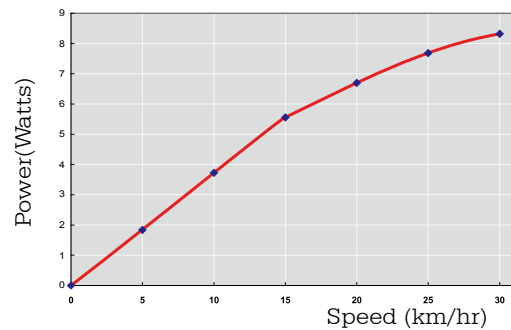
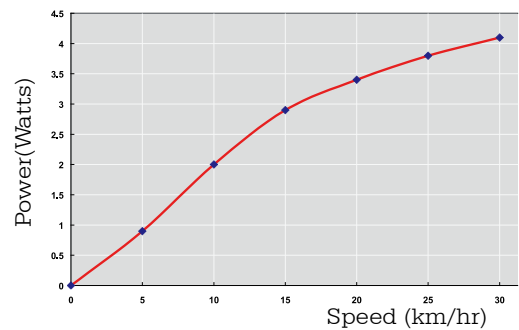
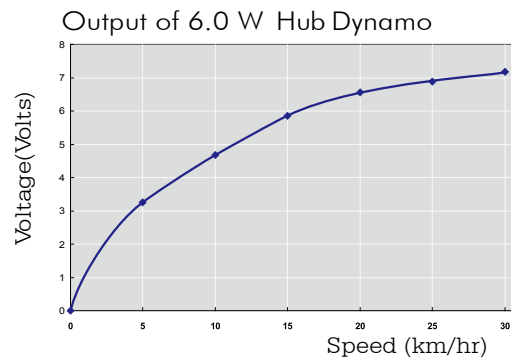
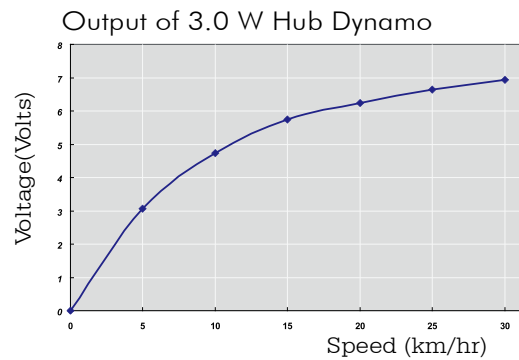

# Dynohub Drum Brake



**XL-FDD**  
**HDS96T 6V\*6.0W**  
 90mm Front Drum Brake Hub  
 [Sealed Cartridge Bearing]



**XL-FDD**  
**HDS93T 6V\*3.0W**  
 90mm Front Drum Brake Hub  
 [Sealed Cartridge Bearing]



**X-FDD**  
**HDS73T 6V\*3.0W**  
 70mm Front Drum Brake Hub  
 [Sealed Cartridge Bearing]



**XL-SDD**  
**HDH93T 6V\*3.0W**  
 90mm Side Drum Brake Dynohub  
 [Sealed Cartridge Bearing]



**X-SDD**  
**HDH73T 6V\*3.0W**  
 70mm Side Drum Brake Dynohub  
 [Sealed Cartridge Bearing]



**HSE003 800mm**  
 3809.1105.003



**HMN386**  
 3809.0205.141

**HMN434 [Stainless]**  
 3809.0205.160



**HMW527**  
 3809.0405.078



**HMW528**  
 3809.0405.081

Color  
 Option



[B]



**HMW560**  
 3809.0405.161



**HSE002**  
 3810.0505.011



**Washer 1/16"**  
**HMW146**  
 3809.0405.145

- 8-Speed with wide gear ratio of 325%.
- Logical gear steps of 30%, 14%, 14%, 14%, 14%, 14%, 30%.
- Patented modular technology.
- Rotary gear selector with no protrusions outside the frame.
- Quick and easy gear change with low change load.
- Direct drive in 1st gear allows use of smaller chainwheels.
- Available with integrated drum brake or use with disc brake.
- Polished aluminum hub shells.
- Twist shifter with light action and small rotating angle.
- Brake lever integrated with replaceable cartridge rubber padding.

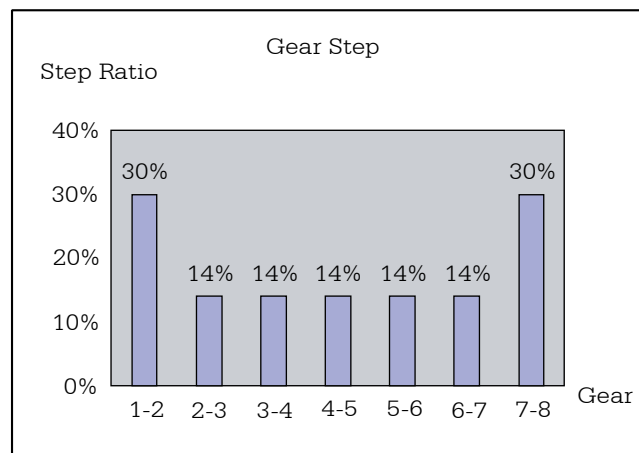
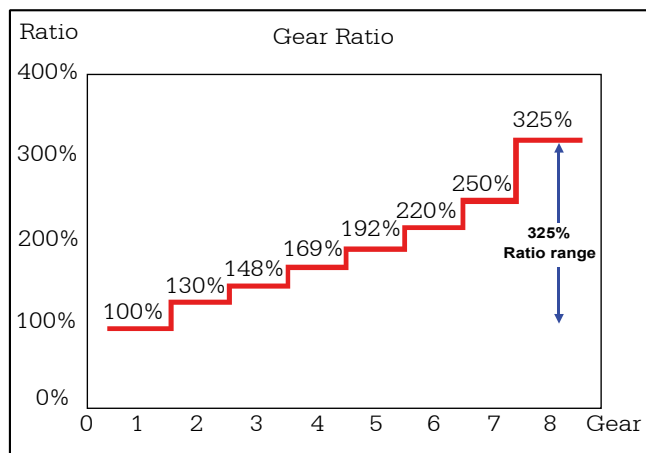





DLS80  
HSJ203



TSS86  
HSJ980



SLS80-T [Ø22.2] HSJ204  
SLS80-H [Ø31.8] HSJ205



X-RD8 [W]  
8-Speed  
70mm Drum Brake Hub



X-RK8 [W]  
8-Speed  
Disc Brake Hub



X-RF8 [W]  
8-Speed Hub





Dust Cap  
HSL882  
3809.0805.032



25T CP 1/8" Dished  
HSL822  
CSIMW.25D



25T CP 1/8" Flat  
HSL972  
CSIMW.25F



23T CP 1/8" Dished  
HSL821  
CSIMW.23D

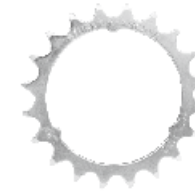

20T CP 3/32" Flat  
HSL897  
CSIMN.20F



Sprocket Circlip  
HSL880 [Xylan]  
3809.0707.003

25T CP 3/32" Dished  
HSL867  
CSIMN.25D

25T CP 3/32" Flat  
HSL971  
CSIMN.25F

23T CP 3/32" Dished  
HSL868  
CSIMN.23D

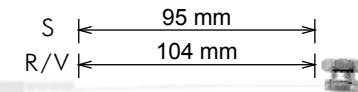

Rotary Cable Anchorage  
HSL977  
3899.000.643



Fulcrum Lever  
HSJ956  
3810.0190.007



Fulcrum Lever Cilp  
HSJ957  
3810.0190.008



Dome Nut  
HMN433 [Stainless]  
3809.0205.159



Lock Washer  
13/32" x 6mm x 9.7mm  
HMW534 [Xylan]  
3809.0410.013



Lock Washer  
13/32" x 4mm x 9.5mm  
HMW529 [Xylan]  
3809.0407.015

## Fitting Sets

[Reversed / Standard (Angled End)]

HFXW8.SSSS



HSL880



HSL882



HSJ956



HSJ957



HMW529 (x 2)



HMN433 (x 2)

[Vertical End]

HFXW8.SSVS



HSL880



HSL882



HSJ956



HSJ957



HMW534 (x 2)



HMN433 (x 2)

- 5-Speed with gear ratio of 243%.
- Even gear steps of 25%, 25%, 25%, 25%.
- Rotary gear selector with no protrusions outside the frame.
- Designed for heavy duty use.
- Aluminum Hub Shell.
- Available with integrated 90mm and 70mm drum brakes, disc brake, freewheel, and EN approved coaster brake.

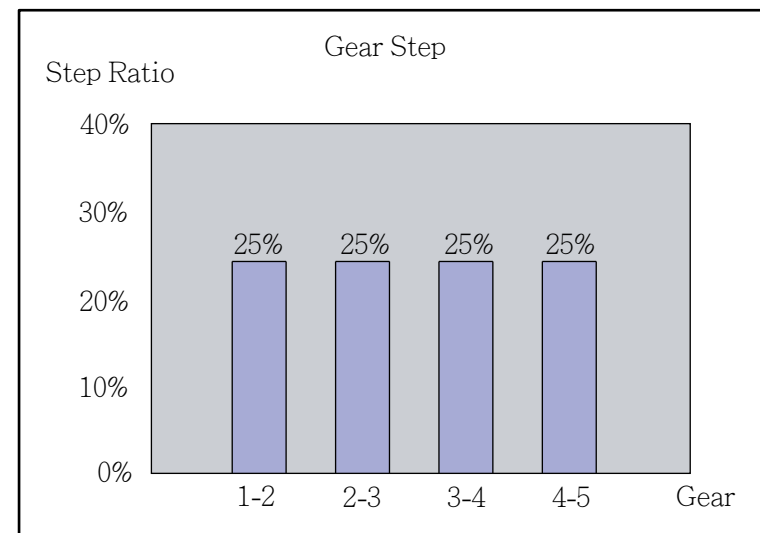
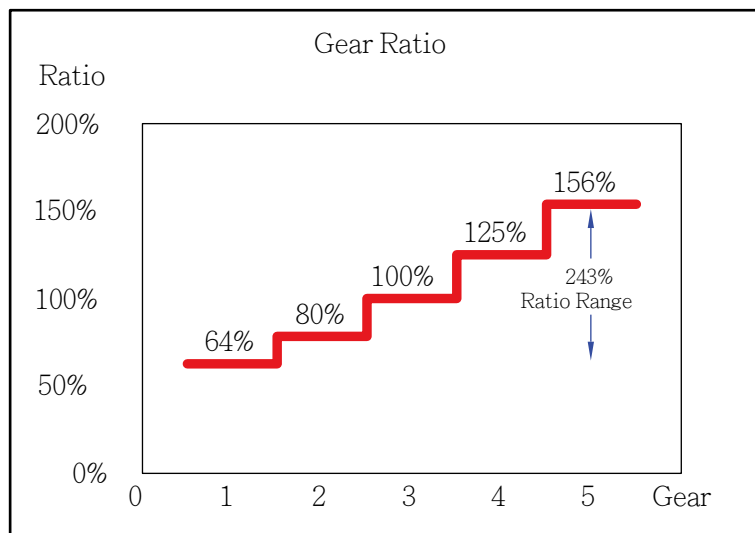





TSC50  
HSJ218



SLC50-T HSJ201    SLC50-H HSJ202



DLC50  
HSJ206



RXL-RD5  
5-Speed  
90mm Drum Brake Hub



RX-RD5  
5-Speed  
70mm Drum Brake Hub



RX-RK5  
5-Speed  
Disc Brake Hub



RX-RF5  
5-Speed Hub



RX-RC5  
5-Speed  
Coaster Brake Hub



Dust Cap  
HSL982  
3809.0805.061



Sprocket Circlip  
HSL981 [Xylan]  
3809.0707.004



Sprocket

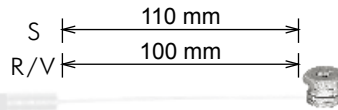

Rotary Cable Anchorage  
HSL977  
3899.0000.643

Flat 1/8" (CP)	17T	CSIRW.17F	HSL993	Dished 1/8" (CP)	19T	CSIRW.19D	HSL999
	18T	CSIRW.18F	HSL991		20T	CSIRW.20D	HSL200
	19T	CSIRW.19F	HSL992	Dished 3/32" (CP)	19T	CSIRN.19D	HSL201
	20T	CSIRW.20F	HSL997		20T	CSIRN.20D	HSL202
Flat 3/32" (CP)	24T	CSIRW.24F	HSL203				
	17T	CSIRN.17F	HSL986				
	18T	CSIRN.18F	HSL987				
	19T	CSIRN.19F	HSL988				



Fulcrum Lever  
HSJ212  
3810.0190.013



Fulcrum Lever Clip  
HSL983  
3809.0705.038  
HSL996 [Stainless]  
3809.0705.041



Dome Nut  
HMN388  
3809.0205.140  
HMN433 [Stainless]  
3809.0205.159



Lock Washer  
13/32" x 4mm x 9.5mm  
HMW518  
3809.0405.118  
HMW529 [Xylan]  
3809.0407.015



Lock Washer  
13/32" x 6mm x 9.7mm  
HMW534 [Xylan]  
3809.0410.013

**Fitting Sets**

[Reversed / Standard (Angled) End]



HFI C5.SSSS  
HFXC5.SSSS

HSL981  
HSL981

HSL982  
HSL982

HSJ212  
HSJ212

HSL983  
HSL996

HMW518 (x2)  
HMW529 (x2)

HMN388 (x2)  
HMN433 (x2)

[Vertical End]



HFI C5.SSVS  
HFXC5.SSVS

HSL981  
HSL981

HSL982  
HSL982

HSJ212  
HSJ212

HSL983  
HSL996

HMW534 (x2)  
HMW534 (x2)

HMN388 (x2)  
HMN433 (x2)

- 4-Speed with gear ratio of 210%.
- Even gear steps of 28%, 28%, 28%.
- Patented modular technology.
- Rotary gear selector with no protrusions outside the frame.
- Direct drive in 1st gear allows use of smaller chainwheels.
- Available with integrated 70mm drum brake, disc brake, and freewheel.

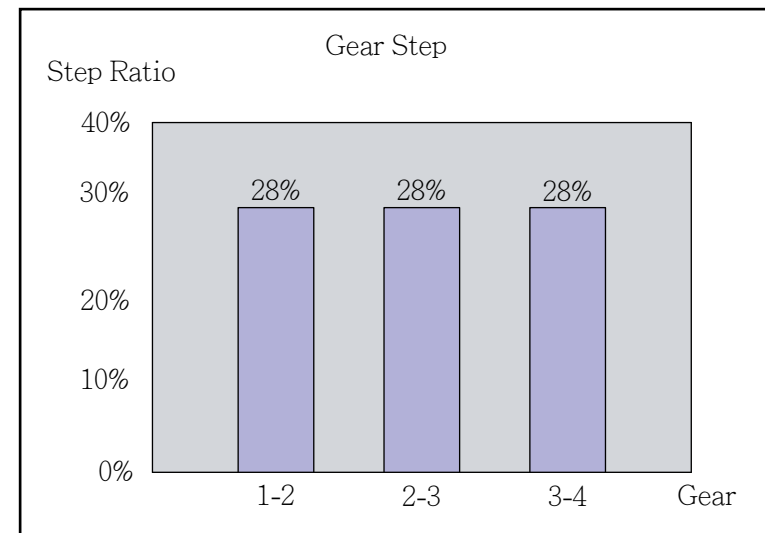
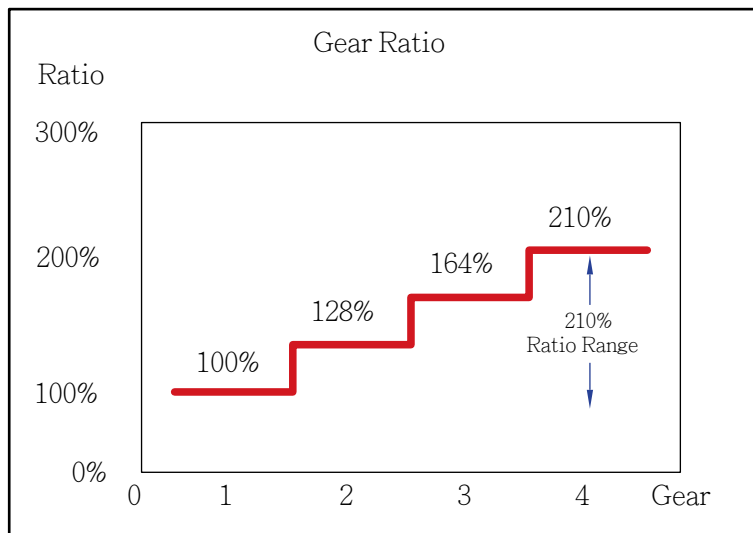





TSS400  
HSJ233



TSS42  
HSJ200



SLS40-T  
HSJ208



SLS40-H  
HSJ209



DLS40  
HSJ207



X-RD4  
4-Speed  
70mm Drum Brake Hub



X-RK4  
4-Speed  
Disc Brake Hub



X-RF4  
4-Speed Hub



S40 Fulcrum Lever Set  
HSJ213  
3899.0000.691



Sprocket Circlip  
HSL721  
3809.0705.005  
HSL879 [Xylan]  
3809.0707.002



HSL984  
3809.0805.059



Sprocket Options (p.47 )



HSL990  
3809.0705.027  
HSL206 [Stainless]  
3809.0705.044



Lock Washer  
M10 x 4mm x 9.5mm  
HMW552  
3809.0405.156

HMW551 [Xylan]  
3809.0407.023



Lock Washer  
M10 x 4mm x 9.5mm  
HMW561  
3809.0405.157

HMW563 [Xylan]  
3809.0407.026

R



Lock Washer  
M10 x 4mm x 9.5mm  
HMW562  
3809.0405.158

HMW564 [Xylan]  
3809.0407.027

L



Lock Washer  
M10 x 6mm x 9.7mm  
HMN566  
3809.0410.019



Dome Nut M10  
HMN442  
3809.0205.164

HMN441 [Stainless]  
3809.0205.163



Rotary Cable Anchorage  
HSL977  
3899.0000.643

## Fitting Sets

[Reversed End]



HFI S4 .SSSS  
HFXS4 .SSSS

HSL721  
HSL879

HSL984  
HSL984

HSJ213  
HSJ213

HSL990  
HSL206

HMW552 (x2)  
HMW551 (x2)

HMN442 (x2)  
HMN441 (x2)

[Standard (Angled) End]



HFI S4 .SSAS  
HFXS4 .SSAS

HSL721  
HSL879

HSL984  
HSL984

HSJ213  
HSJ213

HSL990  
HSL206

HMW561 HMW562  
HMW563 HMW564

HMN442 (x2)  
HMN441 (x2)

[Vertical End]



HFI S4 .SSVS  
HFXS4 .SSVS

HSL721  
HSL879

HSL984  
HSL984

HSJ213  
HSJ213

HSL990  
HSL206

HMW566 (x2)  
HMW566 (x2)

HMN442 (x2)  
HMN441 (x2)

- 3-Speed with standard gear ratio of 177%.
- Gear steps of 33% and 33%.
- Rotary gear selector change mechanism between the rear forks .
- Available with integrated 90mm or 70mm drum brake, disc brake and freewheel.
- Aluminum shells.
- Twist shifter and trigger shifter option.

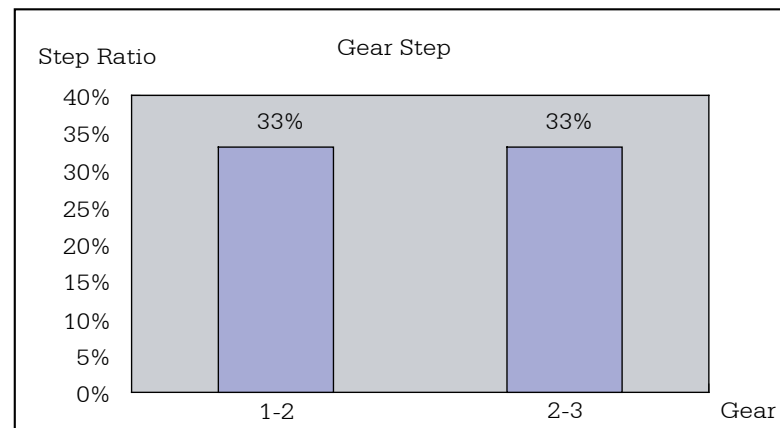
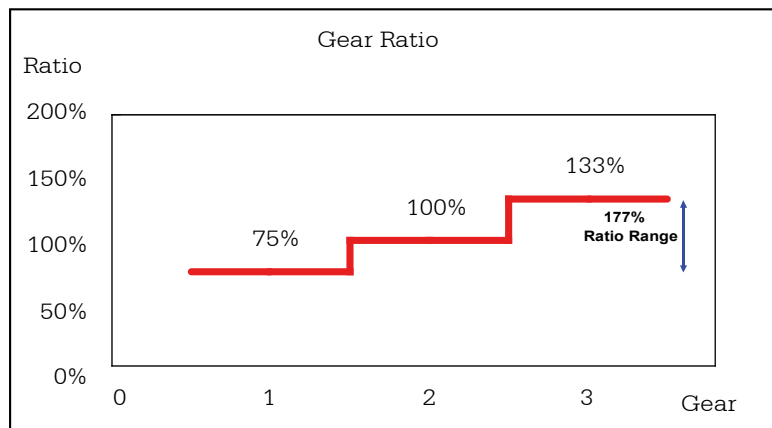



DLC30  
HSJ210



TSC30B  
HSJ228



TSC300  
HSJ229



TSC30 HSJ976    TSC34  
W/adjuster



RX-RD3  
3-Speed  
70mm Drum Brake Hub



RS-RF3  
3-Speed Hub



SLC30-T HSJ216    SLC30-H  
HSJ217



RXL-RD3  
3-Speed  
90mm Drum Brake Hub



RS-RK3  
3-Speed  
Disc Brake Hub





Sprocket Options (p.47)



Sprocket Circlip  
HSL721  
3809.0705.005  
HSL879 [Xylan]  
3809.0707.002



C30 Cable Adjuster  
HSL872  
3899.0000.204

Rotary Cable Anchorage  
HSL977  
3899.0000.643



C30 Fulcrum Lever Set for Standard (Angled) End  
HSJ221      HSJ222 [Stainless]  
3899.0000.776      3899.0000.777



C30 Fulcrum Lever Set for Reversed / Vertical End  
HSJ932      HSJ220 [Stainless]  
3899.0000.775      3899.0000.773



3.2mm  
HMN406  
3809.0205.151  
HMN417 [Xylan]  
3809.0212.005



5mm  
HMN446 [Xylan]  
3809.0212.029



Lock Washer  
3/8" x 4mm x 9.5mm  
HMW530 [Xylan]      HMW521  
3809.0407.002      3809.0405.121



Lock Washer  
3/8" x 6mm x 9.7mm  
HMW558  
3809.0410.014



HMN387  
3809.0205.142  
HMN435 [Stainless]  
3809.0205.161

## Fitting Sets

[Reversed End]					
HFI C3.SSSS HFXC3.SSSS	HSL721 HSL879	HSJ932 HSJ220	HMN406 HMN417	HMW521 (x2) HMW530 (x2)	HMN387 (x2) HMN435 (x2)
[Standard (Angled) End]					
HFI C3.STSS HFXC3.STSS	HSL721 HSL879	HSJ221 HSJ222	HMN406 HMN417	HMW521 (x2) HMW530 (x2)	HMN387 (x2) HMN435 (x2)
[Vertical End]					
HFI C3.SSVS HFXC3.SSVS	HSL721 HSL879	HSJ932 HSJ220	HMN406 HMN417	HMW558 (x2) HMW558 (x2)	HMN387 (x2) HMN435 (x2)

- Classic 3-Speed with standard gear ratio of 177%.
- Gear steps of 33% and 33%.
- Disc brake hub in aluminum shell with 135mm O.L.D.
- Available as standard hub, integrated 90mm & 70mm drum brake.
- EN approved coaster brake.
- Available in aluminum or steel hub shells.
- Wide selection of gear controls including thumb, trigger, twist, stick lever, and bar end shifters.

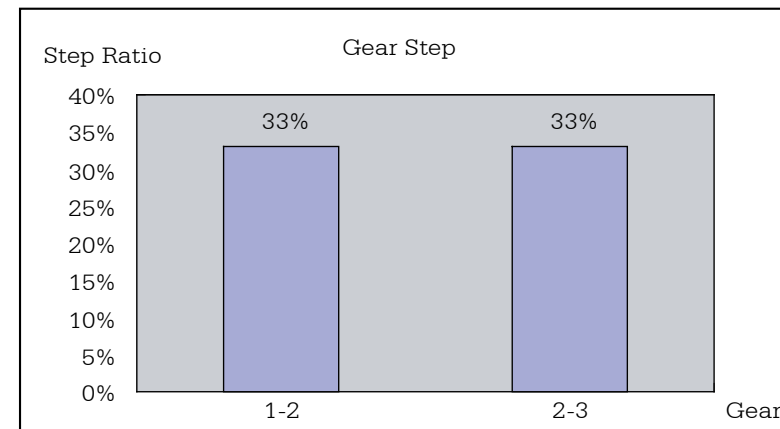
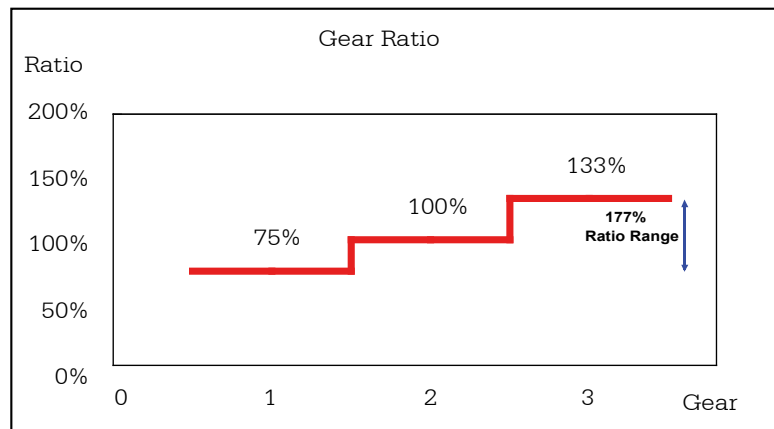



SLS30-B  
HSJ963  
Bar End



SLS30-T [ø22.2] HSJ962  
H [ø31.8] HSJ995  
Thumb Shifter



SLS30-P [ø27.2]  
HSJ993  
Seat Post



SLS30-S [ø28.6mm]  
HSJ981  
Brazed On



DLS30  
HSJ943



XL-RD3  
3-Speed  
90mm Drum Brake Hub



X-RD3  
3-Speed  
70mm Drum Brake Hub



TSS37  
HSJ978



TSS3B  
HSJ232



TSS300  
HSJ230



TSS30B  
HSJ231



S-RK3 / S-RK3 [N]  
3-Speed  
Disc Brake Hub



S-RC3 [II]  
3-Speed  
Coaster Brake Hub



S-RF3 / S-RF3 [N]  
3-Speed Hub  
N [9-Spline Driver]

Color  
Option





TSS36  
HSJ977



TSS33  
HSJ939



SLS3C  
HSJ762  
Classic Trigger



SLS3N  
HSJ823  
Thumb Shifter



AWC [II]  
3-Speed  
Coaster Brake Hub



AW  
3-Speed Hub



**SX**

**QS**



**SX-RK3**  
3-Speed  
Disc Brake Hub



**SX-RB3**  
3-Speed  
Band Brake Hub



**QS-RC5**  
5-Speed  
Reversible  
Coaster Brake Hub



**QS-RC3**  
3-Speed  
Reversible  
Coaster Brake Hub



**CLS31**  
HSJ944



**CLS30**  
HSJ945



**CLS3S**  
HSJ946



**CLS3M**  
HSJ947



# TS



TS-RC5  
5-Speed  
Coaster Brake Hub



TS-RC3  
3-Speed  
Coaster Brake Hub



T-S2C  
2-Speed Kick Shift  
Coaster Brake Hub

T-S1C  
Single Speed  
Coaster Brake Hub



TS-RF5  
5-Speed Hub









































































TS-RF3  
3-Speed Hub



TS-RB3  
3-Speed  
Band Brake Hub

**Fitting Sets**

[Non-Coaster 148mm]								 
HFIS3.2HHA	HSA126	HSL721			HMN420	HSL884	HMN128	HMW526 (x 2)
[Non-Coaster 163mm]								 
HFIS3.3CSS	HSA315	HSL721			HMN129	HSL711	HMN388	HMW518 (x 2)
[Non-Coaster 163mm]								 
HFIS3.3SSS	HSA315	HSL721	HSA650	HMN128	HSJ905	HSA620	HMN388	HMW518 (x 2)
HFXS3.3SSS	HSA315	HSL879	HSA650	HMN411	HSJ905	HSA620	HMN433	HMW529 (x 2)
[Coaster Brake 163mm]								 
HFIS3.4CSS	HSA316	HSL721			HMN129	HSL711	HMN388	HMW518 (x 2)
[Coaster Brake 163mm]								 
HFIS3.4SSS	HSA316	HSL721	HSA650	HMN128	HSJ905	HSA620	HMN388	HMW518 (x 2)
HFXS3.4SSS	HSA316	HSL879	HSA650	HMN411	HSJ905	HSA620	HMN433	HMW529 (x 2)
[Non-Coaster 175mm] [Coaster Brake 175mm]								 
HFIS3.5CSS	HSA420	HSL721			HMN129	HSL711	HMN388	HMW518 (x 2)
[Non-Coaster 175mm] [Coaster Brake 175mm]								 
HFIS3.5SSS	HSA420	HSL721	HSA650	HMN128	HSJ905	HSA620	HMN388	HMW518 (x 2)
HFXS3.5SSS	HSA420	HSL879	HSA650	HMN411	HSJ905	HSA620	HMN433	HMW529 (x 2)
[Non-Coaster 185mm]								 
HFIS3.9HSV	HSA715	HSL721			HMN420	HSL884	HMN388	HMW534 (x 2)
[5 Spd 175/185mm]								 
HFIS5.YSSS	HSA585	HSL721	HSA650	HMN128	HSJ905	HSA620	HMN388	HMW518 (x 2)

- 3-Speed fixed gear with close gear ratio of 160%.
- Gear steps of 20% and 33%.
- Threaded driver compatible for non-fixed 3-speed conversion with standard single speed freewheel.
- Polished and anodized aluminum shell in option colors.
- Aluminum lock-ring and spacers achieve chain lines of 42, 43, 44, and 45mm.
- 1/8" sprocket available from 12T~22T in chrome plated finish.
- 3/32" sprocket available with 13T~22T in chrome plated finish.
- Aluminum thumb shifter for bar end, flat bar, or seat post mount.
- Matching track style chainwheels in 130mm or 144mm PCD from 42~48T.
- Matching track style front hub that is polished and anodized in option colors.

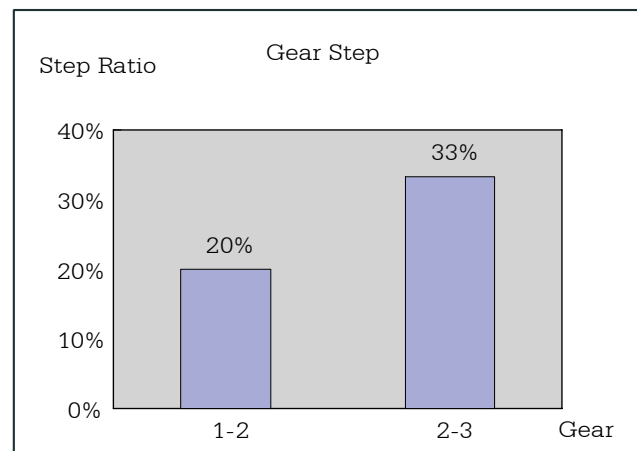
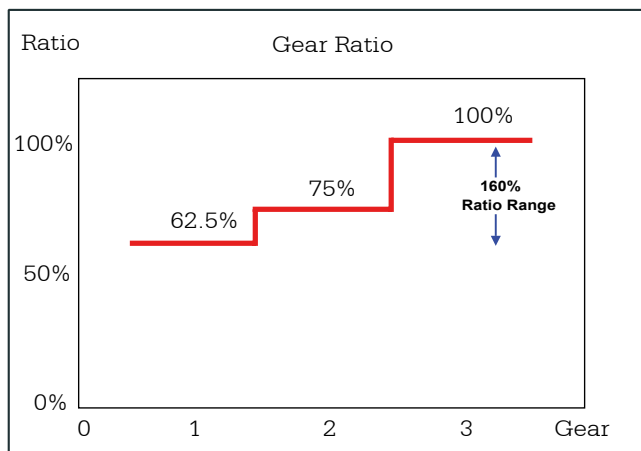

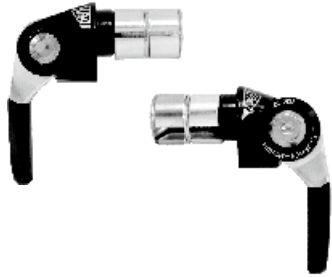

SLS3X-B  
HSJ966  
Bar End



SLS3X-T [Ø22.2] HSJ965  
Thumb Shifter

SLS3X-H [Ø31.8] HSJ990



SLS3X-P [Ø27.2] HSJ991  
Seat Post



SLS3X-S [Ø28.6mm] HSJ988  
Brazed On



S3X  
3-Speed  
Fixed Gear Hub

Color Options



[B]



[G]



[R]



[2]



**S3X** | Fixed Gear 3-Speed



S3X Black [B]  
3-Speed  
Fixed Gear Hub



S3X Gold [G]  
3-Speed  
Fixed Gear Hub



S3X Red [R]  
3-Speed  
Fixed Gear Hub



S3X Blue [2]  
3-Speed  
Fixed Gear Hub



Mark Orange I  
HSA652  
3810.0605.036

Mark Orange II  
HSA713  
3810.0605.037

\*Standard Guide Nut Only



Mark White I  
HSA653  
3810.0605.038

Mark White II  
HSA714  
3810.0605.039

\*Standard Guide Nut Only



Guide Nut - Short  
HMN420  
3809.0225.003

HMN436[Xylan]  
3809.0225.010



Guide Nut - Standard  
HMN129  
3809.0213.001

HMN418 [Xylan]  
3809.0217.002



Lock Washer  
13/32" x 4mm x 9.5mm  
HMW518  
3809.0405.118  
HMW529 [Xylan]  
3809.0407.015



Nut  
HMN128  
3809.0205.144  
HMN411 [Xylan]  
3809.0212.011



Dome Nut  
HMN388  
3809.0205.140  
HMN433 [Stainless]  
3809.0205.159



Dust Cap  
HSL701  
3809.0810.001



Lock-Ring  
HSL896  
3809.0812.005



Sprocket Spacer  
Options  
(Page 48)



CSIX Sprocket  
Options  
(Page 48)

## Fitting Sets

[Standard 120mm]



HFS3X.SSSS

HSA652

HSL701

HSL896

HMW538 (x 2)

HMW537 (x 2)

HMN420

HMN388

HMW518 (x 2)

[Wide 130mm]



HFS3X.WSSS

HSA653

HSL701

HSL896

HMW538 (x 2)

HMW537 (x 2)

HMN420

HMN388

HMW518 (x 2)

- 3-Speed internal gear cassette freehub with gear ratio of 177%.
- Gear steps of 33% and 33%.
- Available as standard hub or disc brake hub.
- Compatible with standard MTB/ATB 9 and 8-speed cassettes.
- Compatible with standard MTB/ATB left hand shifters for front triple chainwheel.
- Compatible with standard 135mm frame dropouts.
- Polished and anodized aluminum shell in alloy silver or black.

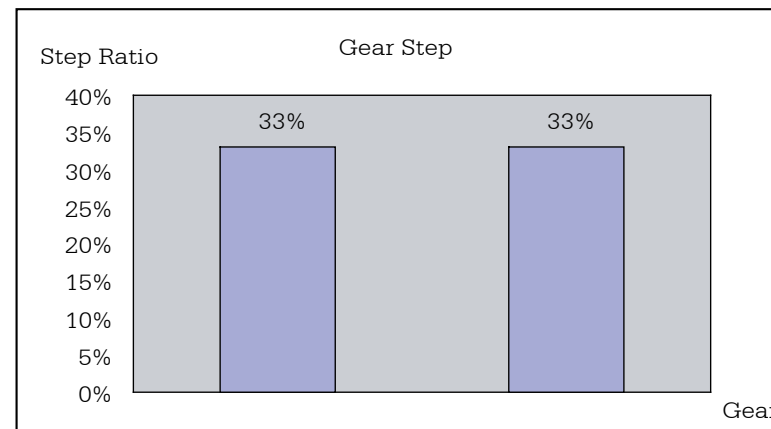
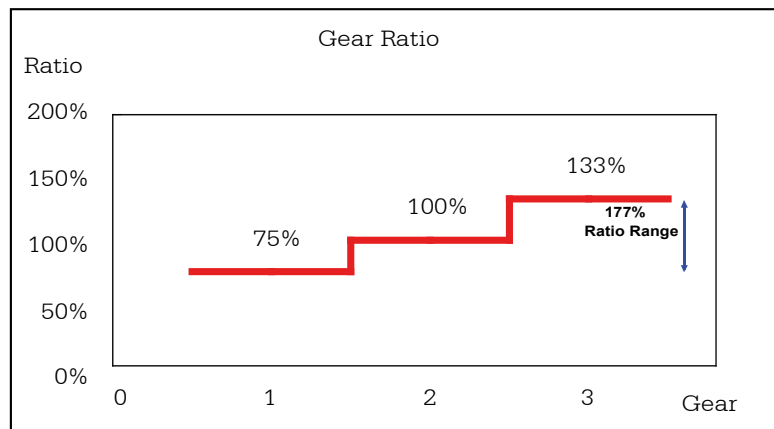



CS-RF3  
3-Speed  
Cassette Freehub



CS-RF3 Black [B]  
3-Speed  
Cassette Freehub



CS-RK3  
3-Speed  
Disc Brake Cassette Freehub



CS-RK3 Black [B]  
3-Speed  
Disc Brake Cassette Freehub

## Fitting Sets



HFIF3.8SSV



HSA716



HMN420



HSL884



HMN388



HMW534 (x 2)

HSL922  
3809.0812.013  
Dust Cap

- 2-Speed internal gear hub with gear ratio of 138%.
- Kick Shift between gears without shifters.
- No shifter cable and wear related issues.
- Available as standard hub, disc brake hub or integrated coaster brake hub.
- Available in aluminum polished and anodized hub shell.

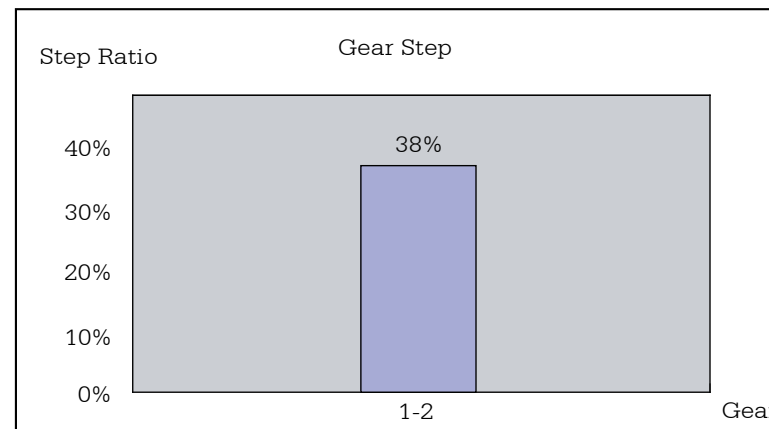
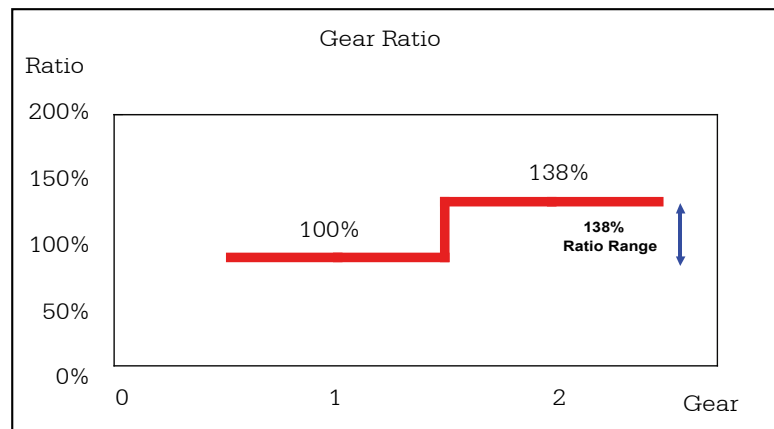
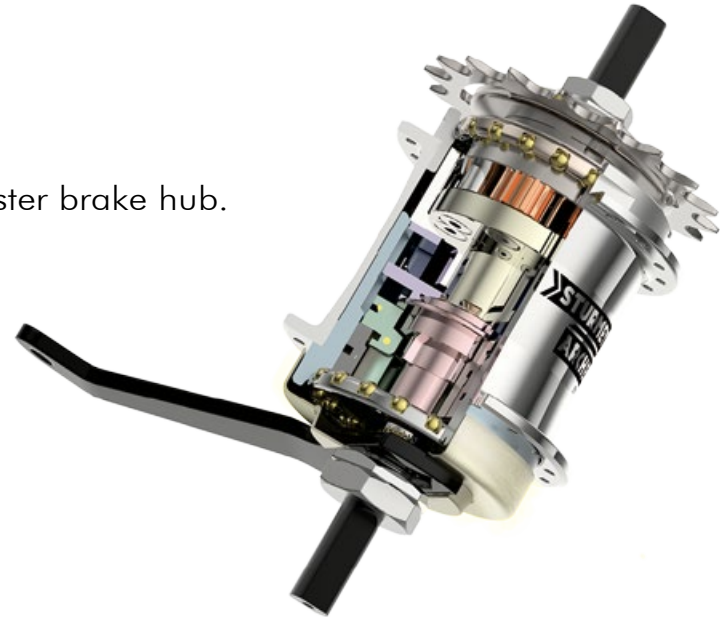



# S20 | Kick Shift 2-Speed



S2  
2-Speed Kick Shift Hub



S2C  
2-Speed Kick Shift  
Coaster Brake Hub



S2K  
2-Speed Kick Shift  
Disc Brake Hub

Color Options



[B]



[G]



[R]



[2]

## Fitting Sets

[Freewheel/ Disc]					
HFS20.S0SS	HSL721			HMW518 (x 2)	HMN388 (x 2)
[Coaster]					
HFS2C.SCSS	HSL721	HSL921 3809.0812.009 Dust Cap	HMW127 (x2) 3809.0405.014 Sprocket Spacer	HMW518 (x 2)	HMN388 (x 2)

- Single coaster brake designed for adult bikes.
- High precision, low friction, roller operated brake.
- Chromoly M10 axle.
- Aluminum hub shells with anodized color options.



S1C  
Single Speed  
Coaster Brake Hub

Color Options



[B]

[G]

[R]

[2]



Sprocket Options (Page 47)



HBT30-F  
[M9 Axle]



HBT30-R  
[For Fix & Freewheel]  
[M10 Axle]  
S[120/165L] / T[120/175L] / R[135/175L]



HBT20-R  
[For Freewheel]  
[M10 Axle]  
S[120/165L] / T[120/175L] / R[135/175L]



Color Options



[B]



[G]



[R]



[2]

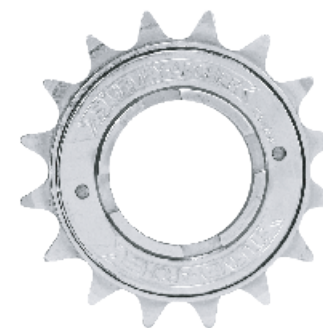

SFX30  
[M30 x 1.0]

SFS30  
[BC1.37]



M10 Dome Nut  
HMN441 [Stainless]  
3809.0205.163



M9 Dome Nut  
HMN434 [Stainless]  
3809.0205.160



HBT Lockring  
HSL970  
3809.0890.003



M9  
HMN426  
3899.0000.471

M10  
HMN427  
3899.0000.472

	1/8"	3/32"
13T	SFX30.W13	SFX30.N13
14T	SFX30.W14	SFX30.N14
15T	SFX30.W15	SFX30.N15
16T	SFS30.W16	SFS30.N16
17T	SFS30.W17	SFS30.N17
18T	SFS30.W18	SFS30.N18
19T	SFS30.W19	SFS30.N19
20T	SFS30.W20	SFS30.N2
21T	SFS30.W21	SFS30.N21
22T	SFS30.W22	SFS30.N22

# Drum Brake Hubs

Front & Rear



XL-FD  
90mm Front  
Drum Brake Hub



X-FD  
70mm Front  
Drum Brake Hub



X-RDC  
70mm Rear  
Drum Brake for Cassettes  
S [Nuttet]



X-RD  
70mm Rear  
Drum Brake for Freewheel  
R [Single Speed]  
7 [7-Speed]

Color  
Option



# Drum Brake Hubs



XL-SD [Q]  
THH90 L  
90mm Left  
Drum Brake Hub  
Q [QR Axle Type]



XL-SD [Q]  
THH90 R  
90mm Right  
Drum Brake Hub  
Q [QR Axle Type]



XL-SD [S/C/B]  
THH80 L  
90mm Left  
Drum Brake Hub  
S [Solid Axle 130mm]  
C [Solid Axle 100mm]  
B [Solid Axle 90mm]



XL-SD [S/C/B]  
THH80 R  
90mm Right  
Drum Brake Hub  
S [Solid Axle 130mm]  
C [Solid Axle 100mm]  
B [Solid Axle 90mm]

Color  
Option



X-SD [Q]  
THH60 L  
70mm Left  
Drum Brake Hub  
Q [QR Axle Type]

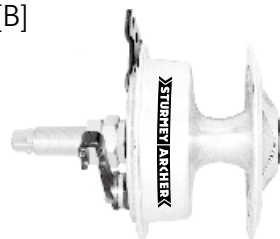

X-SD [Q]  
THH60 R  
70mm Right  
Drum Brake Hub  
Q [QR Axle Type]



X-SD [S/C/B]  
THH50 L  
70mm Left  
Drum Brake Hub  
S [Solid Axle 130mm]  
C [Solid Axle 100mm]  
B [Solid Axle 90mm]



X-SD [S/C/B]  
THH50 R  
70mm Right  
Drum Brake Hub  
S [Solid Axle 130mm]  
C [Solid Axle 100mm]  
B [Solid Axle 90mm]

# Left & Right Side

\* for Side Dynohub Drum Brakes, please refer to page 7.

XL-SD Hub Shell 36H Assy. (w/ 6001-ZZ x2)	HSB520	3899.0000.406
XL-SD Hub Shell 32H Assy. (w/ 6001-ZZ x2)	HSB541	3899.0000.502
XL-SD Hub Shell 28H Assy. (w/ 6001-ZZ x2)	HSB540	3899.0000.501

90mm Left Brake Plate Assy. (w/ QR Base)	HSB519	3899.0000.669
90mm Right Brake Plate Assy. (w/ QR Base)	HSB518	3899.0000.670
Quick Release Axle [Stainless]	HSL994	3809.0205.166
90mm Left Brake Plate Assy.	HSB517	3899.0000.604
90mm Right Brake Plate Assy.	HSB516	3899.0000.607
Inner Washer "A2"	HMW539	3809.0405.110
Outer Washer	HMW533	3809.0405.036
130 mm Solid Axle	HSL881	3805.0205.030
100 mm Solid Axle	HSL885	3805.0205.029
90mm Solid Axle	HSL898	3805.0205.035
M12 Nut	HMN421	3809.0205.124
M12 Nut w/ Non-Slip	HMN422	3809.0205.119
Rubber End Cap	HSL979	3810.0505.040

X-SD Hub Shell 36H Assy. (w/ 6001-ZZ x2)	HSB500	3899.0000.393
X-SD Hub Shell 32H Assy. (w/ 6001-ZZ x2)	HSB539	3899.0000.500
X-SD Hub Shell 28H Assy. (w/ 6001-ZZ x2)	HSB538	3899.0000.488

70mm Left Brake Plate Assy. (w/ QR Base)	HSB514	3899.0000.667
70mm Right Brake Plate Assy. (w/ QR Base)	HSB515	3899.0000.668
Quick Release Axle [Stainless]	HSL994	3809.0205.166
70mm Left Brake Plate Assy. "A2"	HSB530	3899.0000.665
70mm Right Brake Plate Assy. "A2"	HSB531	3899.0000.666
Inner Washer "A2"	HMW539	3809.0405.110
Outer Washer	HMW533	3809.0405.036
130 mm Solid Axle	HSL881	3805.0205.030
100 mm Solid Axle	HSL885	3805.0205.029
90mm Solid Axle	HSL898	3805.0205.035
M12 Nut	HMN421	3809.0205.124
M12 Nut w/ Non-Slip	HMN422	3809.0205.119
Rubber End Cap	HSL979	3810.0505.040



# Front Cranksets FCS



[Black]

FCS720 42T no CGs

FCS721 42T W. Steel CGs

FCS722 42T W. Alloy OCG & Steel ICG

[Steel Chainring]

[Forged Alloy Crank]

[CSM435 Bolts & Nuts]

[Compatible Chain 3/32"]

FCS740 44T no CGs

FCS741 44T W. Steel CGs

FCS742 44T W. Alloy OCG & Steel ICG

[Steel Chainring]

[Forged Alloy Crank]

[CSM435 Bolts & Nuts]

[Compatible Chain 3/32"]

FCS750 44T no CGs

FCS752 44T W. Alloy CGs

[Alloy Chainring]

[Forged Alloy Crank]

[CSM435 Bolts & Nuts]

[Compatible Chain 3/32"]



[Black]

FCSS54 54T

FCSS52 52T

[Double Chain Guard]



[Black]

FCSS56 56T

[Single Chain Guard]

[CNC Option]

# Front Cranksets FCS



FCS440 44T no CGs

FCS441 44T W. Steel CGs

FCS442 44T W. Alloy OCG & Steel ICG

[Steel Chainring]

[Forged Alloy Crank]

[CSM435 Bolts & Nuts]

[Compatible Chain 3/32"]

FCS450 44T no CGs

FCS452 44T W. Alloy CGs

[Alloy Chainring]

[Forged Alloy Crank]

[CSM435 Bolts & Nuts]

[Compatible Chain 3/32"]



[Black]

FCS602 42T

FCS612 42T

FCS603 33T

FCS613 33T

FCS606 36T

FCS616 36T

FCS608 38T

FCS618 38T

[3/32"]

[1/8"]

[Forged Alloy Crank]

2[Ø92mm Cover Ring]

5[Ø95mm Cover Ring]

# Front Cranksets FCT



AD [Alloy + Black]

- FCT88 48T [Integrated Through Axle]
- FCT86 46T [6061 Forged Alloy Crank]
- FCT84 44T [7075 Chainring]
- FCT82 42T [7075 Bolts & Nuts]
- [PCD 144mm]
- [Polished Anodized Finish Crank]
- [Black Anodized + CNC Chainring]



BBRS



AA [Alloy + Alloy]

- FCT62 42T [6061 Forged Alloy Crank]
- FCT64 44T [7075 Chainring]
- FCT66 46T [7075 Bolts & Nuts]
- FCT68 48T [PCD 144mm]
- [Polished Anodized Finish Crank & Chainring]



AD [Alloy + Black]

- FCT62 42T [6061 Forged Alloy Crank]
- FCT64 44T [7075 Chainring]
- FCT66 46T [7075 Bolts & Nuts]
- FCT68 48T [PCD 144mm]
- [Polished Anodized Finish Crank]
- [Black Anodized + CNC Chainring]



BD  
[Black + Black]



GD  
[Gold + Black]



RD  
[Red + Black]



2D  
[Blue + Black]



BA  
[Black + Alloy]



GA  
[Gold + Alloy]



RA  
[Red + Alloy]



2A  
[Blue + Alloy]



BD  
[Black + Black]



GD  
[Gold + Black]



RD  
[Red + Black]



2D  
[Blue + Black]

# Front Cranksets FCT



AD [Alloy + Black]

- FCT42 42T [6061 Forged Alloy Crank]
- FCT44 44T [7075 Chainring]
- FCT46 46T [7075 Bolts & Nuts]
- FCT48 48T [PCD 144mm]  
[Polished Anodized Finish]  
[Black Anodized + CNC Chainring]



BD [Black + Black]



- FCT12 42T [6061 Forged Alloy Crank]
- FCT14 44T [7075 Chainring]
- FCT16 46T [SCM435 Bolts & Nuts]  
[PCD 130mm]
- FCT18 48T [Sandblast Anodized Matt Black Finish]  
[Black Anodized + CNC Chainring]



AD [Alloy + Black]

- FCT22 42T [6061 Forged Alloy Crank]
- FCT24 44T [7075 Chainring]
- FCT26 46T [SCM435 Bolts & Nuts]
- FCT28 48T [PCD 130mm]  
[Polished Anodized Finish]  
[Black Anodized + CNC Chainring]



BD [Black + Black]



- BBS18  
[Steel Axle]  
[Alloy RH & LH Cups]  
[Alloy Sleeve]  
[Eng. Polymer Stopper]  
[Sealed Cartridge Bearings]



- BBS15  
[Steel Axle]  
[Steel RH & LH Cups]  
[Steel Sleeve]  
[Chrome Plated]  
[Eng. Polymer Stopper]  
[Sealed Cartridge Bearings]



BAS15  
BB Axle Bolt  
[M8]

# Other Components



S[Silver]

B[Black]

**BLS92**

[For Drum/Roller/Cantilever]

**BLM92**

[For V-Brake]



S[Silver]



B[Black]

**BLS81**

[For Drum/Roller/Cantilever]

**BLM81**

[For V-Brake]



S[Silver]



B[Black]

**BLS81 -P**

[For Drum/Roller/Cantilever]

Parking Brake Button



**CTS8X [B]**



**CTS8X [S]**



**CTS86**



**CTS70**  
[Steel Cage]



# Parts

p.49



p.50



p.44



p.44



p.48



p.48



p.50



p.51



# Nuts | Washers

## Front Hub



### M9

Front Hub  
 XL-FD X-FD  
 XL-FDD X-FDD  
 HBT30-F HDS10  
 HDS20  
 Rear Hub  
 X-RD



Hex15

HMN386  
 3809.0205.141

HMN434 [Stainless]  
 3809.0205.160



Hepta

Anti-Theft  
 HMN449 [Stainless]  
 3809.0295.003



Hex15

HMN426  
 3899.0000.471



HMW528  
 3809.0405.081



Washer 1/32"  
 HMW550 (0.8mm)  
 3809.0405.013

## Front Hub

### 3/8"

BF SBF

## Rear Hub

RS-RF3, RX-RD3,  
 RX-RD3, RS-RK3



Hex15

HMN387  
 3809.0205.142

HMN435 [Stainless]  
 3809.0205.161



Hepta

Anti-Theft  
 HMN448 [Stainless]  
 3809.0295.002



Hex15

HMN118  
 3809.0205.150

HMN416 [Xylan]  
 3809.0212.020



Washer 1/16"  
 HMW146 (1.6mm)  
 3809.0405.145



Washer 1/8"  
 HMW129 (3.2mm)  
 3809.0405.123

## Rear Hub



### 13/32"

All Rear Hubs  
 [Excluding C30, S40,  
 S1C, HBT, X-RDC]



Hex15

HMN388  
 3809.0205.140

HMN433 [Stainless]  
 3809.0205.159



Hepta

Anti-Theft  
 HMN447 [Stainless]  
 3809.0295.001



Hex15

HMN128  
 3809.0205.144

HMN411 [Xylan]  
 3809.0212.011



Washer 3/16"  
 HMW483 (4.8mm)  
 3809.0405.162

### M10

HBT30-R  
 X-RDC  
 S40  
 S1C



Hex15

HMN441 [Stainless]  
 3809.0205.163



Hepta

Anti-Theft  
 HMN450 [Stainless]  
 3809.0295.004



Hex15

HMN427  
 3899.0000.472



Washer 1/4"  
 HMW484 (6.4mm)  
 3809.0405.150

# Classic Parts

## Indicators

### 3 Speed



Mark I  
HSA125  
3810.0605.019



Mark II  
HSA126  
3810.0605.020



Mark III  
HSA315  
3810.0605.021



Mark IV  
HSA316  
3810.0605.022



Mark V  
HSA420  
3810.0605.023



Mark VI  
HSA615  
3810.0605.024



Mark VIII  
HSA716  
3810.0605.040



Mark IX  
HSA715  
3810.0605.031

### 5 Speed



Mark Yellow  
HSA585  
3810.0605.026



Mark Green  
HSA651  
3810.0605.034



Mark Blue  
HSA317  
3810.0605.025



Mark Red  
HSA490  
3810.0605.027



Mark Purple  
HSA717  
3810.0605.032



Mark Navy Blue  
HSA712  
3810.0605.033

## Cable Anchorage & Adjusters



HSL759  
3899.0000.098



HSJ925  
3899.0000.166

HSJ926  
3899.0000.152 (Slotted)



HSJ542  
3104.0505.037



HSJ828  
3104.0405.002



HSJ954  
3899.0000.353 (Aluminum)

HSJ998  
3899.0000.570 (Aluminum / Slotted)

## Shifter Cable/Casing Set



Twist Shifter  
HSJ882 (1420mm)



SLS3N, SLS5N, SLW5N Shifter  
HSJ802 (1400mm)



Orion Shifter  
HSJ883 (1420mm)



Classic Trigger  
HSJ102 (1420mm)  
HSJ101 (530mm)



# Classic Parts



Guide Nut-Standard  
HMN129  
3809.0213.001  
HMN418 [Xylan]  
3809.0217.002



Guide Nut - Short  
HMN420  
3809.0225.003  
HMN436 [Xylan]  
3809.0225.010



Cover for Short Guide Nut  
HSL884  
3810.0505.028



HSL906 [Silver]  
3810.0507.003



Indicator Guard  
HSL711  
3810.0505.002



Gear Selector Guide Full Cover  
HSA620  
3810.0505.042



Gear Selector Guide  
HSA650  
3899.0000.384



Fulcrum Lever  
HSJ842  
3810.0105.012



Fulcrum Lever with Locating Washer  
HSJ905  
3810.0105.011



Nut (8mm)  
HMN128  
3809.0205.144  
HMN411 [Xylan]  
3809.0212.011



Nut (6mm)  
HMN440  
3809.0205.157



Locating Washer  
HSJ929  
3810.0105.008





CP

Sprocket Teeth	24	22	21	20	19	18	17	16	15	14	13
Sprocket Thickness 1/8" Deep Dished					 CSISW.19P HSL965 [CP]	 CSISW.18P HSL924 [CP]	 CSISW.17P HSL827 [CP]				
Dished	 CSISW.24D HSL876 [CP]	 CSISW.22D HSL830 [CP]	 CSISW.21D HSL832 [CP]	 CSISW.20D HSL834 [CP]	 CSISW.19D HSL836 [CP]	 CSISW.18D HSL838 [CP]	 CSISW.17D HSL840 [CP]				
Flat		 CSISW.22F HSL942 [CP]	 CSISW.21F HSL941 [CP]	 CSISW.20F HSL940 [CP]	 CSISW.19F HSL842 [CP]	 CSISW.18F HSL844 [CP]	 CSISW.17F HSL846 [CP]	 CSISW.16F HSL848 [CP]	 CSISW.15F HSL850 [CP]	 CSISW.14F HSL852 [CP]	 CSISW.13F HSL854 [CP]
Sprocket Thickness 3/32" Dished					 CSISN.19D HSL858 [CP]	 CSISN.18D HSL860 [CP]	 CSISN.17D HSL862 [CP]				
Flat		 CSISN.22F HSL951 [CP]	 CSISN.21F HSL950 [CP]	 CSISN.20F HSL949 [CP]	 CSISN.19F HSL948 [CP]	 CSISN.18F HSL947 [CP]	 CSISN.17F HSL946 [CP]	 CSISN.16F HSL864 [CP]	 CSISN.15F HSL945 [CP]	 CSISN.14F HSL944 [CP]	 CSISN.13F HSL943 [CP]

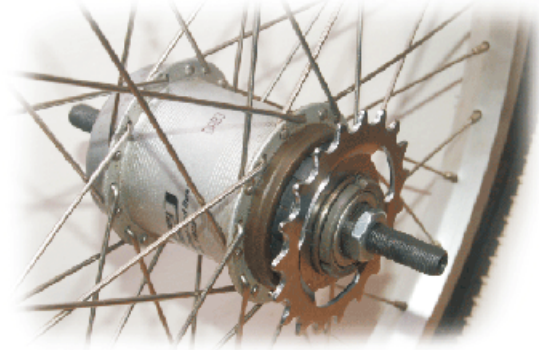

## 9-Spline Sprockets

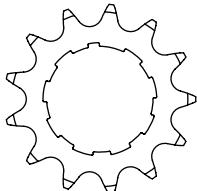
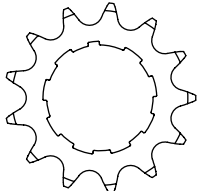
 1/8" x 1/2" Flat [CP]	13T	CSIXW.13F	HSL887
	14T	CSIXW.14F	HSL888
	15T	CSIXW.15F	HSL889
	16T	CSIXW.16F	HSL890
	17T	CSIXW.17F	HSL891
	18T	CSIXW.18F	HSL892
	19T	CSIXW.19F	HSL908
	20T	CSIXW.20F	HSL909
	21T	CSIXW.21F	HSL910
	22T	CSIXW.22F	HSL911
	 3/32" x 1/2" Flat [CP]	12T	CSIXN.12F
13T		CSIXN.13F	HSL894
14T		CSIXN.14F	HSL912
15T		CSIXN.15F	HSL913
16T		CSIXN.16F	HSL914
17T		CSIXN.17F	HSL915
18T		CSIXN.18F	HSL916
19T		CSIXN.19F	HSL917
20T		CSIXN.20F	HSL918
21T		CSIXN.21F	HSL919
22T		CSIXN.22F	HSL920

## 9-Spline Spacers

Sprocket Spacer 2mm (12T Only)	HMW536	3809.0406.009
Sprocket Spacer 3mm (12T Only)	HMW535	3809.0406.010
Sprocket Spacer 2mm (13-22T)	HMW538	3809.0406.011
Sprocket Spacer 3mm (13-22T)	HMW537	3809.0406.012

## Sprocket Fittings

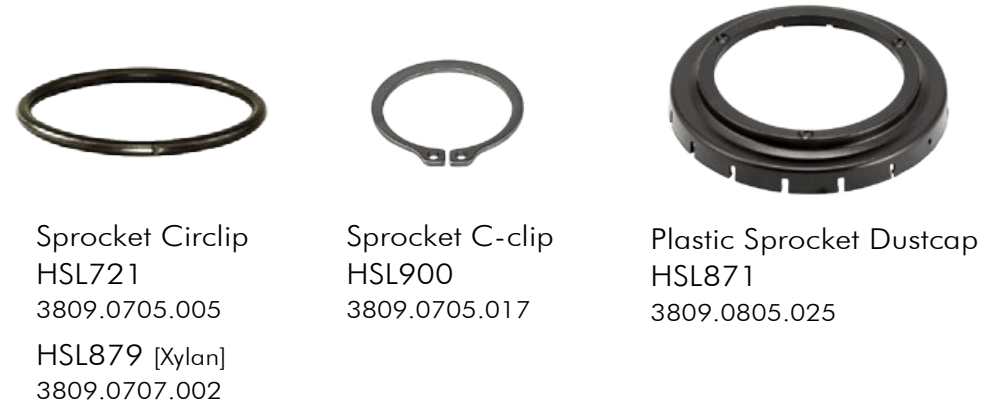

Sprocket Circlip  
HSL721  
3809.0705.005  
HSL879 [Xylan]  
3809.0707.002

Sprocket C-clip  
HSL900  
3809.0705.017

Plastic Sprocket Dustcap  
HSL871  
3809.0805.025

## Lockwasher For Chain Adjuster



13/32" x 6mm x 9.7mm  
HMW534 [Xylan]  
3809.0410.013  
[Vertical Dropout]

13/32" x 4mm x 9.5mm  
HMW518  
3809.0405.118  
HMW529 [Xylan]  
3809.0407.015

13/32" x 1.8mm x 9.5mm  
HMW515  
3809.0405.120



13/32" x 2mm x 9.5mm  
HMW526  
3809.0405.119  
HMW544 [Xylan]  
3809.0410.005

Lock Washer  
M10 x 4mm x 9.5mm  
HMW552  
3809.0405.140  
HMW551 [Xylan]  
3809.0407.023

Lock Washer  
M10 x 4mm x 9.5mm  
HMW561  
3809.0405.157  
HMW563 [Xylan]  
3809.0407.026

Lock Washer  
M10 x 4mm x 9.5mm  
HMW562  
3809.0405.158  
HMW564 [Xylan]  
3809.0407.027

M10 x 6mm x 9.7mm  
HMN566  
3809.0410.019  
[Vertical Dropout]

3/8" x 6mm x 9.7mm  
HMW558  
3809.0410.014  
[Vertical Dropout]

3/8" x 4mm x 9.5mm  
HMW521  
3809.0405.121  
HMW530 [Xylan]  
3809.0407.002



# Brake Cable Assembly



BSD1X / BSD1XH / BSD1XH1  
[Ø1.6 Slick Stainless Cable + 2P Casing + Xylan Adjuster Assembly]

HSK765	/ BSD1X.0900.BA1	/ 900mm
HSK765H	/ BSD1XH.0900.BA1	/ 900mm
HSK765H1	/ BSD1XH1.0900.BA0	/ 900mm
HSK768	/ BSD1X.1600.BA1	/ 1600mm
HSK768H	/ BSD1XH.1600.BA1	/ 1600mm
HSK768H1	/ BSD1XH1.1600.BA0	/ 1600mm



BSD05 / BSD05H / BSD05H1  
[Ø1.6 Galvanized Cable + 2P Casing]

HSK730	/ BSD05.0900.BA1	/ 900mm
HSK730H	/ BSD05H.0900.BA1	/ 900mm
HSK730H1	/ BSD05H1.0900.BA0	/ 900mm
HSK736	/ BSD05.1600.BA1	/ 1600mm
HSK736H	/ BSD05H.1600.BA1	/ 1600mm
HSK736H1	/ BSD05H1.1600.BA0	/ 1600mm



BSD01 [BF]  
[Ø1.6 Galvanized Cable + 2P Casing]  
HSK740 / BSD01.0900.BA0 / 900mm



Brake Adjuster Assembly - Standard Type  
HSB422

3899.0000.154  
HSB536 [Xylan]  
3899.0000.457

[SBF, SAB3, AB3, AB5, X-FD, XL-FD, XL-FDD, RX-RD3, RXL-RD3, X-RD3, XL-RD3, X-RD4, X-RD5, XL-RD5, X-RD8]



Pinch Bolt  
HSK770  
3899.0000.774



Brake Adjuster Assembly - Hex Type  
HSB560

3899.0000.786  
HSB559 [Xylan]  
3899.0000.625

[SBF, SAB3, AB3, AB5, X-FD, XL-FD, XL-FDD, RX-RD3, RXL-RD3, X-RD3, XL-RD3, X-RD4, X-RD5, XL-RD5, X-RD8]



Brake Adjuster Assembly III  
HSB307

3899.0000.172  
HSB537 [Xylan]  
3899.0000.715  
[BF]

# Brake Arm Clips

## Front Brake Arm Clips



17.5mm (11/16")  
HSL702  
3899.0000.106



22.2mm (7/8")  
HSL703  
3899.0000.107



Rubber Sleeve  
HSL770  
3810.0505.005

## Rear Brake Arm Clips



15.5mm  
HSL767  
3899.0000.115



17.0mm (43/64")  
HSL907  
3899.0000.658



22.2mm (7/8")  
HSL769  
3899.0000.116



15.9mm (5/8")  
HCB101  
3899.0000.746



17.0mm (43/64")  
HSL791  
3899.0000.150



19.1mm (3/4")  
HSL761  
3899.0000.659

# Fulcrum Clips & Pulleys

## Fulcrum Clips



### Top tube and Down tube



25.4mm (1")  
 HSJ512  
 3899.0000.100  
 HSJ515 included



28.6mm (1-1/8")  
 HSJ514  
 3899.0000.176  
 HSJ515 included

### Chainstay and Backstay



15.9mm (5/8")  
 HSJ553  
 3899.0000.660



17.9mm (45/64")  
 HSJ548  
 3899.0000.101



19.1mm (3/4")  
 HSJ753  
 3899.0000.697



15.9mm (5/8")  
 HSJ775  
 3899.0000.108  
 HSJ515 included



Fulcrum Sleeve  
 HSJ515  
 3810.0505.003



## Pulleys

### Top tube and Down tube



28.6mm (1-1/8")  
 HSJ521  
 3899.0000.105



25.4mm (1")  
 HSJ520  
 3899.0000.104



**TLSL1**  
 TLSL1.0000.0A0  
 Sprocket & Lock Ring Removal Tool  
 For HBT Rear Hub



**HTR149**  
 3899.0000.627  
 Anti-Theft Dome Nut Tool



**HTR147**  
 3810.0725.005  
 Ratchet Ring Removal Tool



**TLSF2**  
 TLSF2.0000.0A0  
 Single Freewheel Removal Tool



**HTR150**  
 3810.0725.012



**HTR140**  
 3810.0790.002  
 14mm Cone Spanner



**HTR141**  
 3810.0790.003  
 16mm Cone Spanner



**HTR142**  
 3810.0790.004  
 23mm Cone Spanner



**HTR145**  
 3810.0790.008  
 Classic Ball Ring Spanner



**HTR144**  
 3810.0790.006  
 S2C Ball Ring Spanner



**HTR146**  
 3810.0790.009  
 S80(W) Ball Ring Spanner



**HTR139**  
 3810.0790.007  
 Dynohub Cap Spanner



**HTR148**  
 3810.0790.010  
 C50 Ball Ring Spanner



**HTR151**  
 3810.0790.011  
 S40 Ball Ring Spanner

***Note***

***Note***



**Note**

***Note***

Look for SunRace 2017-2018 catalogue.



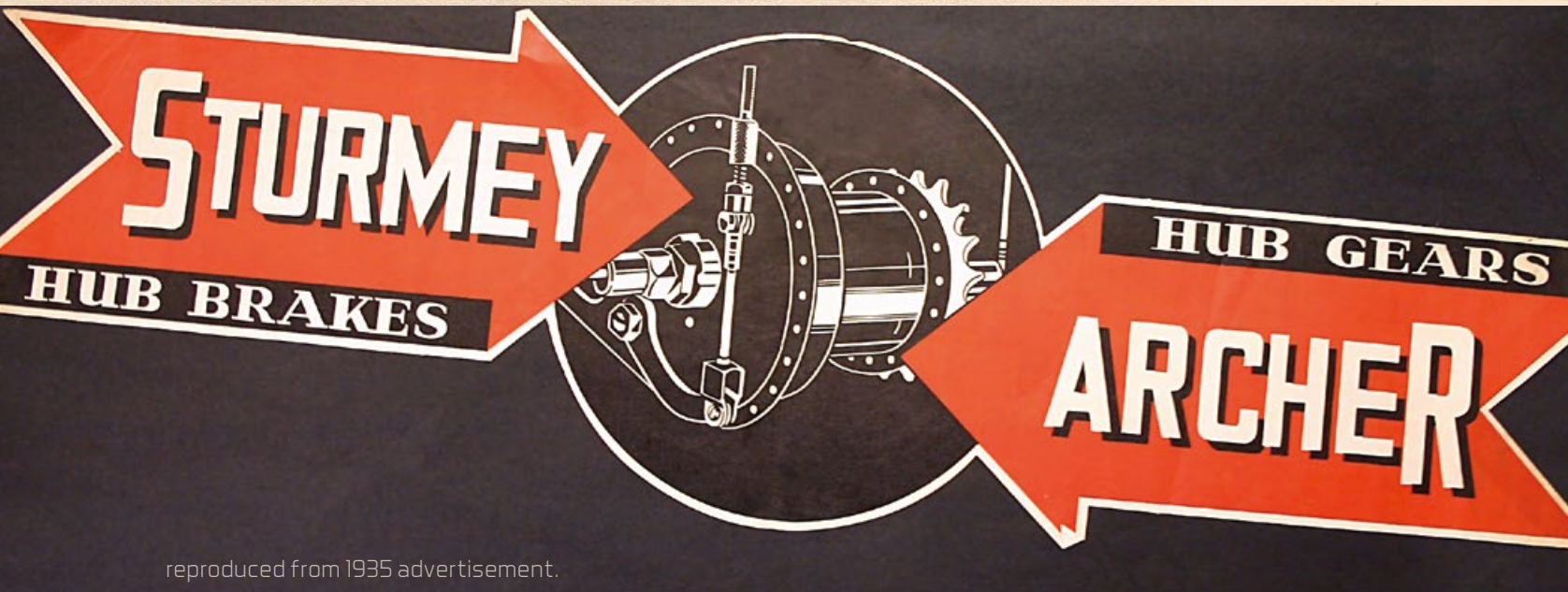

reproduced from 1935 advertisement.

**Sun Race Sturme-Archer Inc.**  
No.51, Haishan Central Street, Luzhu District,  
Taoyuan City, 33856 Taiwan  
Tel:+886 (3) 354-3900  
Fax:+886 (3) 354-2858  
E-mail:info@sunrace.com

**Sun Race Sturme-Archer Europe**  
Nijverheidsweg 19A,  
3641 RP Mijdrecht, The Netherlands  
Tel:+31 (20) 609-0221  
Fax:+31 (20) 609-0211  
E-mail:info@sunrace.nl

**Sun Race Sturme-Archer USA**  
952 School Street, #409  
Napa, CA 94559 U.S.A.  
Tel:+1 (707) 259-6700  
Fax:+1 (707) 259-6710  
E-mail:info@sunraceusa.com

**The Original And Best**  
**est. 1902**

[www.sunrace.com](http://www.sunrace.com)  
[www.sturme-archer.com](http://www.sturme-archer.com)  
[www.sturme-archerheritage.com](http://www.sturme-archerheritage.com)