

Instructions for Dynohub

1. GENERAL INFORMATION

1.1 Scope of this leaflet

Congratulations on your purchase of a Sturmey-Archer dynohub. For the best performance, please follow instructions in this leaflet. Please contact your dealer if any problems are experienced with these products.

This leaflet refers to the following hub types :

- ⊙ **Dynohub with 90mm drum brake: XL-FDD**
- ⊙ **Dynohub with 70mm drum brake: X-FDD**
- ⊙ **Dynohub: HDS10 series (HDS12)**
- ⊙ **Dynohub for disc brake: HDS20 series (HDS22)**

1.2 Preparation

1. Check the degree of parallel of the front fork end. If the front end is severely out of parallel, deformation of the hub axle may cause noise from an obstruction inside the dynohub to be generated.
2. Install the dynohub to the front fork so that the side with the connection terminal is on the right when facing toward the front of the bicycle. If the side with the connection terminal is facing toward the left, the dynohub may not turn properly while riding.
3. Check that the dynohub connection terminal is securely connected before using the dynohub.
4. Use a 6V/2.4W bulb for the front light and a 6V/3.0W bulb for the front light and taillight.
5. Do not disassemble the internal hub mechanism.
6. The dynohub will cause the turning of the wheel to become slightly heavier because of the magnet inside the hub.

2. INSTALLATION

2.1 XL-FDD, X-FDD

1. Set the wheel-set done.
2. Select a suitable brake arm clip to clamp the brake arm loosely to the front fork.
3. Fit hub into the front fork (1) with the wheel centralized. Fit toothed axle washer (2), Mudguard stay (3), Basket stay (4), Dome-Nut (5), tighten the dome nuts to a torque of **22-23Nm**.
4. Tighten the brake arm clip firmly in this position to either **2 Nm** torque.

If the cable connected to the ground terminal is not properly grounded, check that the Toothed axle washer (2) perforates the paint surface of the front fork. If the Toothed axle washer (2) is not perforating the paint surface, the light will not illuminate properly, so scrape away a small amount of paint from the front fork.

It is recommended that you connect the two wires to ensure that current flows smoothly.

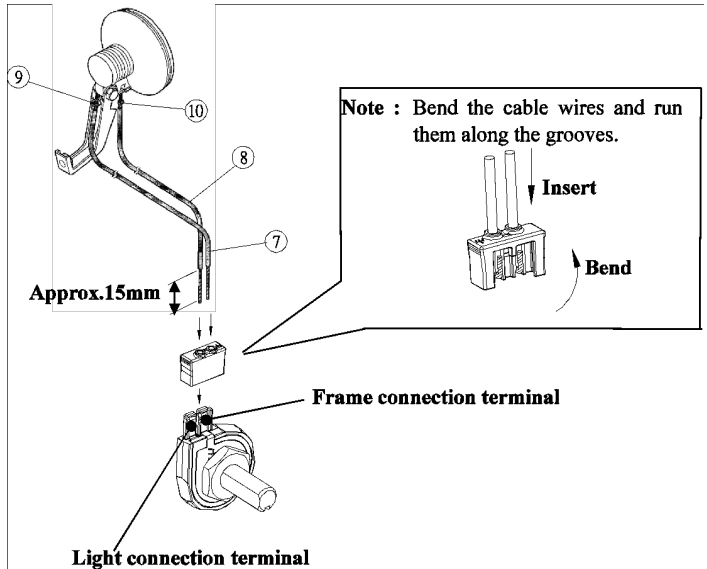
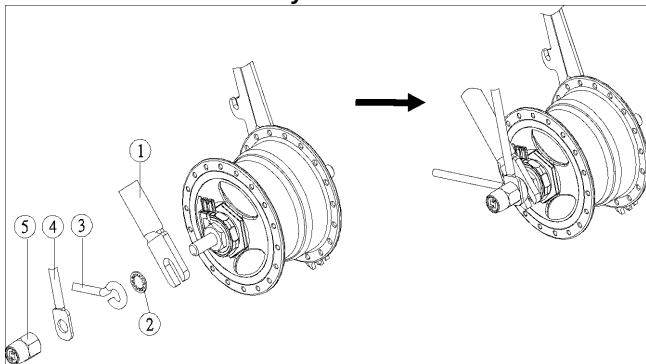

2.4 Checking the light illumination

1. Rotate the front wheel and check the light illumination.

Do not ride the bicycle while the connector cover is removed, otherwise the cable might get caught in the bicycle wheel.

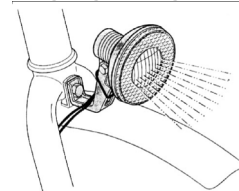

3. BRAKE

3.1 Closed End Cables

1. Attach the cable to the handlebar brake lever.
2. Locate the brake adjusting spigot in the slot of the brake arm.
3. Fit the cable nipple into the hub brake lever assembly.

3.2 Pinch Bolt

1. Attach the cable to the handlebar brake lever.
2. Locate brake adjusting spigot into slot on the brake arm. Push the cable inner wire through the hole in the pinch bolt nut and locate this into the cradle into the brake lever. Pull the inner wire through the pinch bolt until taut.
3. Set adjuster (11) so that there is approximately 5mm of thread showing above the locknut (12).
4. Holding the brake lever in the 'brake on' position with the inner cable taut, hold the pinch bolt 'nut' on the inside of the brake arm with a spanner and tighten pinch bolt 'screw' on the outside arm (**2-3Nm**).

3.3 Brake Adjustment

1. Slacken the brake adjuster locknut (12).
2. Turn the adjuster (11) until the brake is applied.
3. Slacken the adjuster until the wheel can just be turned freely.
4. Tighten the locknut (12).

To maintain maximum braking efficiency avoid sharp bends and kinks in the cable.

Instructions for Dynohub

2.2 HDS10, HDS20

See section 2.1. Skip steps 2.1.2 and 2.1.4.

2.3 Connection of the cable

1. Twist the cable wires (6) before connecting them so that they stay together.
2. Connect the cable as shown in the illustration below.
3. Recommended wire specification

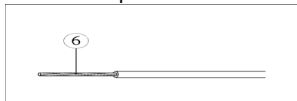

Type	Stranded
Wire	Size (AWG) 22 Diameter approx. 0.8
Insulation	Diameter 1.8 - 2.0mm

4. Do not switch over the frame cable (7) and the light cable (8) by mistake. If the cables are connected incorrectly, the light will not illuminate.
5. Scrape away the paint from the light's frame connection terminal (9) and the light connection terminal (10) when connecting the cables.
6. Connect the cables as shown in the illustration below.

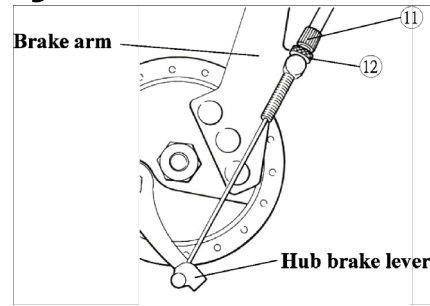

3.4 Disc brake for HDS20

Please check and adjust according to brake manufacturers manual.