



**Model IMI3 (Front)**

**Part Number IMI3KN.SBSS.BA0**

IGH	Speed (Type)	3-Speed (Automatic w/SMI30)
	Gear Ratio	Overall Range 198%
	1	100%
	2	155%
	3	198%
Gear Shifting	Speed	•
	Torque	•
	Cadence	•
Brake	Type	Disc Brake
	Rotor	4-Bolt (PCD 65mm)
Motor	Type	Direct Drive
	Watt (rated)	250W
	Voltage (rated)	48V
	Speed	25kph / 32kph(20mph)
	Phase Current (peak)	45A
	Battery Current (maximum)	25A
	Efficiency	>80%
	Max. Torque (peak)	50Nm
Axle Diameter		M10 Slotted
Axle Length		180mm
Over Locknut Dimension		135mm
R: Axle Protrusion Length		22mm
L: Axle Protrusion Length		23mm
Spoke Holes		(B) 36H
Pitch Circle Diameter		210mm
Flange Width		44mm
Center to	Right	21mm
Flange	Left	23mm
Spoke Compatibility		13G & 14G
Sprocket Teeth		13T ~ 22T (9-spline)
Chain Line: 1/8" Flat Sprocket		42.4mm
Finish		Black
Weight		6.2kg



**Model IMJI3**  
**IGH Speed (Type) 3-Speed (Automatic w/SMI30)**

	Gear Ratio	Overall Range	198%
		1	100%
		2	155%
		3	198%
	Gear Shifting	Speed	●
		Torque	●
		Cadence	●
Brake	Type		Disc Brake
	Rotor		4-Bolt
Motor	Type		Direct Drive
	Watt (rated)		(S) 250W
	Voltage (rated)		48V
	Speed		25kph / 32kph(20mph)
	Phase Current (peak)		36A
	Battery Current (maximum)		15A
	Efficiency		>80%
	Max. Torque (peak)		50Nm
Axle Diameter			M10 Slotted
Axle Length			185mm
Over Locknut Dimension			135mm
R: Axle Protrusion Length			22mm
L: Axle Protrusion Length			23mm
Spoke Holes			(B) 36H
Pitch Circle Diameter			210mm
Flange Width			44mm
Center to	Right		21mm
Flange	Left		23mm
Spoke Compatibility			13G & 14G
Sprocket Teeth			13T ~ 22T (9-spline)
Chain Line: 1/8" Flat Sprocket			42.4mm
Finish			Black
Weight			6.2kg



<b>Model</b>	<b>2-Speed</b>	<b>IMA2</b>	
<b>Part Number</b>		<b>IMA2WHQT.S</b>	
<b>IGH</b>		Speed(Type)	2-Speed(Automatic)
		Gear Ratio	152%
		Overall Range	100%
		1	152%
		2	19.4km/h
		Gear Shifting	18.0km/h
		28"	16.6km/h
		26"	
		24"	
<b>Brake</b>		Type	110mm Drum Brake
		Brake Arm & Cable Type	Standard / (1)Type 1
		Compliance	EN15194:2017(130kg)
<b>Motor</b>		Type	Direct Drive
		Watt(rated)	250W
		Voltage(rated)	48V
		Speed	25kph / 32kph(20mph)
		Phase Current(peak)	40A
		Battery Current(maximum)	25A
		Efficiency	>80%
		Max. Torque(peak)	40Nm
<b>Torque Sensor</b>		Technology	Magnetoelastic
		Torque Range	0~100Nm
		Output Signal(0Nm)(+/-2mV)	0.65V
		Signal Slope(+/-0.5mV/Nm)	40mV/Nm
		Power Supply Range	6V~16V
		Power Consumption(nominal)	<0.4W
		Signal Bandwidth	1kHz
<b>Axle Diameter</b>			M10 Slotted
<b>Axle Length</b>			195mm
<b>Over Locknut Dimension</b>			142mm
<b>R:Axle Protrusion Length</b>			27mm
<b>L:Axle Protrusion Length</b>			26mm
<b>Spoke Holes</b>			( B )36H / ( C )32H
<b>Pitch Circle Diameter</b>			210mm
<b>Flange Width</b>			49mm
<b>Center to Flange</b>		Right	27.4mm
		Left	21.6mm
<b>Spoke Compatibility</b>			13G & 14G
<b>Sprocket Teeth</b>			13T~22T(9-spline)
<b>Chain Line:1/8" Flat Sprocket</b>			42mm~54mm
<b>Finish</b>			Black
<b>Weight</b>			6.7kg

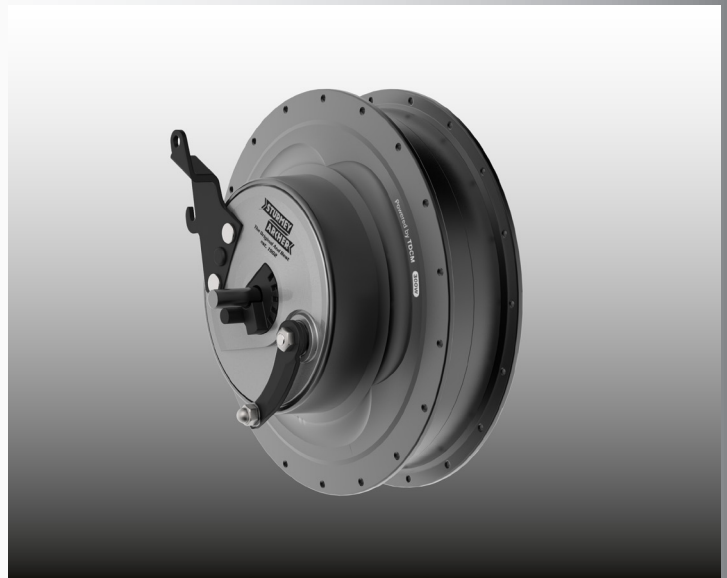

**Model 2-Speed IMA2**

**Part Number IMA2WHQT.S**

IGH	Speed(Type) Gear Ratio	Overall Range	2-Speed(Automatic) 152%
		1	100%
		2	152%
	Gear Shifting	28"	19.4km/h
		26"	18.0km/h
		24"	16.6km/h
Brake	Type		<b>110mm Drum Brake</b>
	Brake Arm & Cable Type		Standard / (1)Type 1
	Compliance		EN15194:2017(130kg)
Motor	Type		Direct Drive
	Watt(rated)		250W
	Voltage(rated)		48V
	Speed		25kph / 32kph(20mph)
	Phase Current(peak)		40A
	Battery Current(maximum)		25A
	Efficiency		>80%
	Max. Torque(peak)		40Nm
Torque Sensor	Technology		Magnetoelastic
	Torque Range		0~100Nm
	Output Signal(0Nm)(+/-2mV)		0.65V
	Signal Slope(+/-0.5mV/Nm)		40mV/Nm
	Power Supply Range		6V~16V
	Power Consumption(nominal)		<0.4W
	Signal Bandwidth		1kHz
Axle Diameter			M10 Slotted
Axle Length			195mm
Over Locknut Dimension			142mm
R:Axle Protrusion Length			27mm
L:Axle Protrusion Length			26mm
Spoke Holes			( B )36H / ( C )32H
Pitch Circle Diameter			210mm
Flange Width			49mm
Center to Flange		Right	27.4mm
		Left	21.6mm
Spoke Compatibility			13G & 14G
Sprocket Teeth			13T~22T(9-spline)
Chain Line:1/8" Flat Sprocket			42mm~54mm
Finish			Black
Weight			6.7kg