

## Part List: A2C Automatic Shift 2-speed Hub

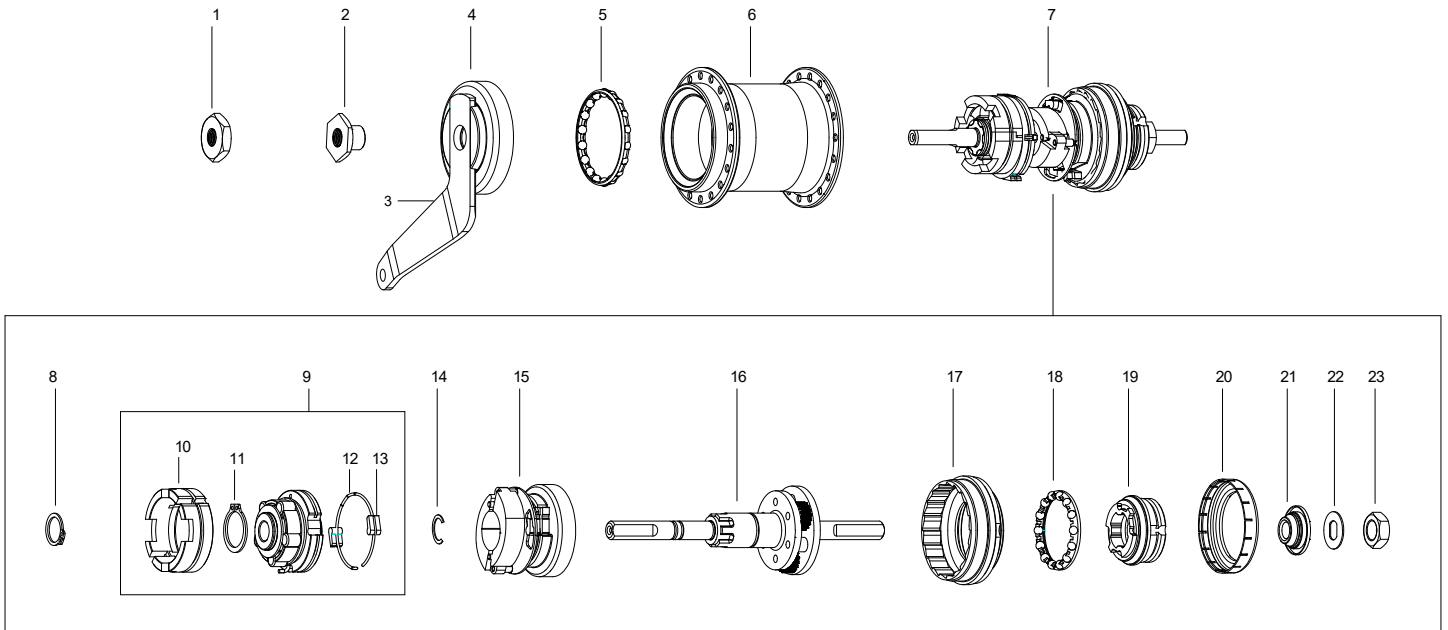

Item Sales			Item Sales			Item Sales		
No.	No.	Description	No.	No.	Description	No.	No.	Description
1	HMN424	Cone Locknut	8	HSL729	C-clip No.10	16	HSA1019	Axle/Planet Cage Assembly
2	HMN425	Brake Adjuster Nut	9	HSH510	Brake Module	17	HSA1020	A2C Ball Ring
3	HSH487	Brake Arm	10	HSH511	Brake Shoes	18	HSA438	Ball Cage Assembly
4	HSH495	Brake Arm/Cone Assembly	11	HSL990	C-clip No.20	19	HSA1021	A2C Driver Assembly
5	HSA164	L.H. Ball Cage Assembly	12	HSA450	Pawl Spring Circlip	20	HSL871	Plastic Sprocket Dustcap
6	HSA1015	A2C(H) Hub Shell Assembly-36H	13	HSA410	Pawl	21	HSA379	Cone
	HSA1016	A2C(L) Hub Shell Assembly-36L	14	HSL227	Circlip No.17.5	22	HMW150	Lockwasher
7	H SX209	A2C(H) Internal Assembly	15	HSA1017	A2C(H) Shift Weight/Gear Ring Assy.	23	HMN407	Cone Locknut(13/32"-6.4mm)
	H SX210	A2C(L) Internal Assembly		HSA1018	A2C(L) Shift Weight/Gear Ring Assy.			